

eFOLDi Scooter

Model: MK1.5



USER MANUAL

eFOLDi[®] 



Contents

■ Terms, conditions and disclaimers	2
■ Welcome	4
■ Product overview	6
■ Components	7
■ Safety guidance	10
■ Unfolding instructions	12
■ Folding instructions	17
■ Folding into a chair	21
■ How to drive your eFOLDi	22
■ Battery info and charging	25
■ Checks and maintenance	28
■ Frequently asked questions	29
■ Technical specifications	31
■ Appendix	32

Terms, conditions and disclaimers



The terms 'us', 'we', 'our', 'SunTech UK' and SunTech UK Ltd' mean SunTech UK Limited, which is a UK registered company, limited by guarantee, registered with Companies House, number 06906908. The terms 'website' means the website found online at 'www.eFOLDi.co.uk' and/or 'www.eFOLDi.com'. The terms 'you', 'your', 'user' and 'rider', mean the person using the eFOLDi notwithstanding any person(s) handling the eFOLDi on behalf of the user, if different to the user, including general handling, maintenance, repairs and so on.

PURCHASER'S AGREEMENT

By accepting delivery of this eFOLDi, you undertake to not change, alter or modify this eFOLDi and/or any parts supplied with it or subsequently for it, and/or render inoperable or unsafe, any guards, shields or other safety features of this product; fail, refuse or neglect to install any retrofit kits from time to time, as may be provided by SunTech UK Ltd to enhance and/or preserve the safe use of this product. You also agree to accept and abide, by/with the terms and conditions contained herein and as may be revised from time to time and updated on our website, being immediately applicable. By using the eFOLDi and/or accessories and/or components supplied with or for the eFOLDi, the user acknowledges having read and understood the use(s) and limitations of the product(s) without exceptions.

This shall not act as a waiver of any implied warranties, which customer retains, as provided by law.

Warranties will be void and SunTech UK Ltd will accept no responsibility whatsoever or howsoever, in instances of misuse and/or abuse of the products, in part or in full, by the user and/or any unauthorised persons, which may include (but not to be limited to); the user(s) failing to comply with all legal requirements and guidelines, wherever and/or however it is used or intended to be used, lack of or inappropriate maintenance, maintenance (apart from the routine maintenance as described in this manual by the user) by anyone not approved to do so, unapproved repairs, unauthorised disassembly of the vehicle and/or components including (but not limited to) battery pack(s) and controllers, unapproved modifications or alterations, failure to ensure correct folding and unfolding procedures are followed precisely and in full, damage or injury howsoever caused, failure to apply all reasonable and appropriate safety precautions at all times, improper use of the vehicle and/or parts and/or accessories, being used by more than one person at any times, use in any competitive sport, racing, stunts, jumping or other similar activity.

Our liability and the liability of our suppliers, to you or any third parties in any circumstances is limited to the user's cost of qualifying products purchased. Qualifying products as acceptable for the return, as outlined in the returned policy, as stated on the website online at: www.eFOLDi.co.uk and/or 'www.eFOLDi.com'.

Information in this user manual is subject to change without prior notice. For the latest updates and information, please go to our website online at: www.eFOLDi.co.uk and/or 'www.eFOLDi.com'.



THE eFOLDi MK 1.5 SHOULD NOT BE USED BY

PEOPLE WHO ARE UNABLE TO:

- Fold or unfold it using both hands*,
- Transfer themselves onto the seat* and remain in a seated upright position at all times, without assistance while the vehicle is in motion,
- Place and keep your feet on the foot-pegs,
- Operate all controls fully and as intended.
- Steer competently and appropriately at all times and in all conditions,
- Maintain appropriate awareness of all relevant circumstances for each journey and take appropriate action as may be required to avoid mishap,
- Lift it in whole or in part as may be required dependent upon user's needs*

****Unless accompanied by a person sufficiently able and competent to carry out that task.***

SHIPPING AND DELIVERY

Before using your eFOLDi, make sure your delivery is complete as some components may be individually packaged. If you do not receive a complete delivery, please contact us immediately. Where damage has occurred during transport, either to the packaging or the content, please contact the delivery company responsible.

Welcome



Thank you for choosing an eFOLDi scooter as your mobility solution.

I'm Sumi Wang, the founder of Suntech UK and co-inventor of the eFOLDi and would like to welcome you to the eFOLDi family of users.

Suntech UK manufactures a range of assistive technologies to help you get the most from life. Our mission is to give our customers freedom, friendship and fun with a range of easy to use, convenient and market leading mobility solutions.

Your eFOLDi has been manufactured to the highest standards and quality checked by our own pre-sales technicians before delivery to provide you with a product that will give many years of freedom and fun with reliable service.

Please take some time to read the user manual and the supplied documents before using your eFOLDi for the first time, this will help you understand the product and help you obtain maximum enjoyment and safety from your new eFOLDi scooter. You will quickly become familiar with the features of your eFOLDi with a little practice.

Suntech UK prides itself on its high-quality products and customer support so please remember to return the warranty form and retain all of the supplied documents in a safe place. These will help us to assist you in the event of any difficulties you may experience in the future.

I am sure you will find your eFOLDi scooter to be a reliable friend and companion and I thank you for your custom and your trust in our products.

Yours,

A handwritten signature in blue ink that reads 'Sumi Wang'.

Sumi Wang

Useful Information for you

Website address	www.efoldi.com
Email	services@efoldi.com
Facebook	www.facebook.com/efoldi.co.uk



Product overview

Storage mode



Trolley mode



Chair mode



The eFOLDi MK 1.5 is the top end product of SunTech Ltd UK and can be found in the market, with a weight of only 17 Kg and is road legal in the UK with a top speed of 8 mph. Amazingly easy to set up and fold and fully airline compliant.

The eFOLDi MK 1.5 is the perfect travel companion at home and abroad.

Scooter mode



Model: MK1.5

Components

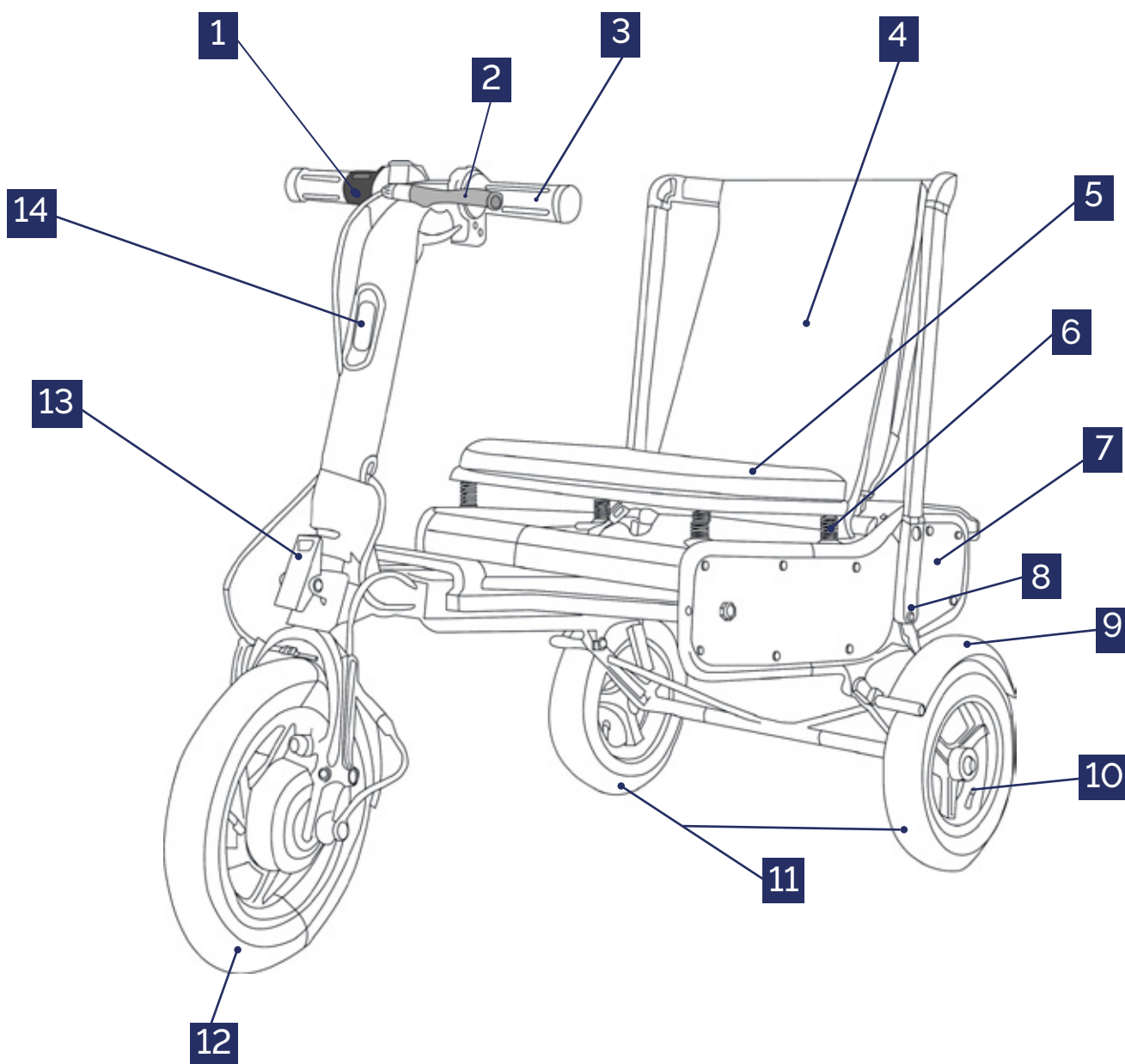

PARTS LIST

1	Accelerator
2	Brake lever
3	Handle bar
4	Backrest
5	Seat
6	Springs
7	Side panel

8	Backrest lever
9	Mud guard
10	Inflater valve
11	Rear wheels
12	Front wheel
13	A-Latch
14	Front light

Control bar components

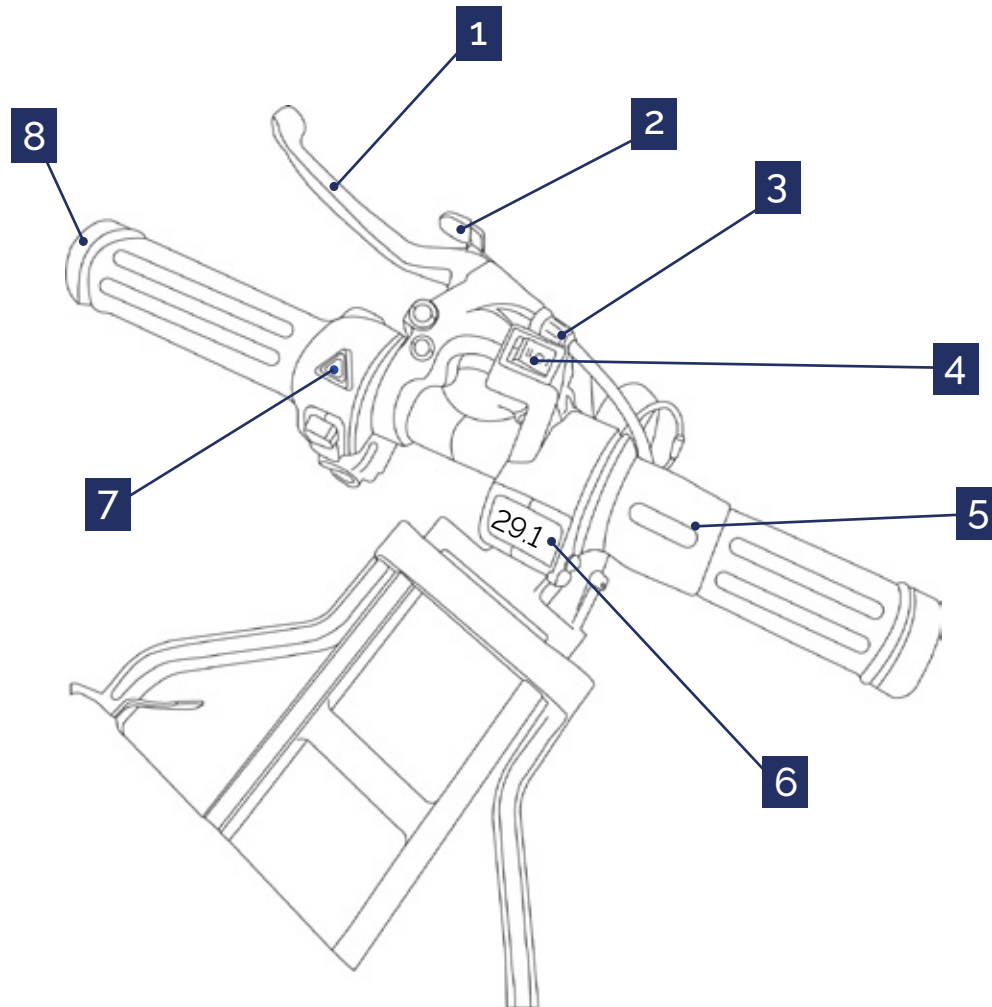

PARTS LIST

1	Brake lever
2	Brake lock
3	Brake adjuster
4	Speed / Reverse switch
5	Twist throttle
6	Voltage display
7	Hazard / light switch
8	Turn indicator

DESCRIPTION

2	<p>Brake lock: Pull brake lever before engaging. Do not fold scooter with brake lock on.</p>
4	<p>Speed switch: 1 - Pavement mode (4mph) 0 - Reverse 11 - Road mode (8mph)</p>
6	<p>Voltage display: 29 = full 24 and below = charge (number will fluctuate depending on terrain)</p>

Battery section components

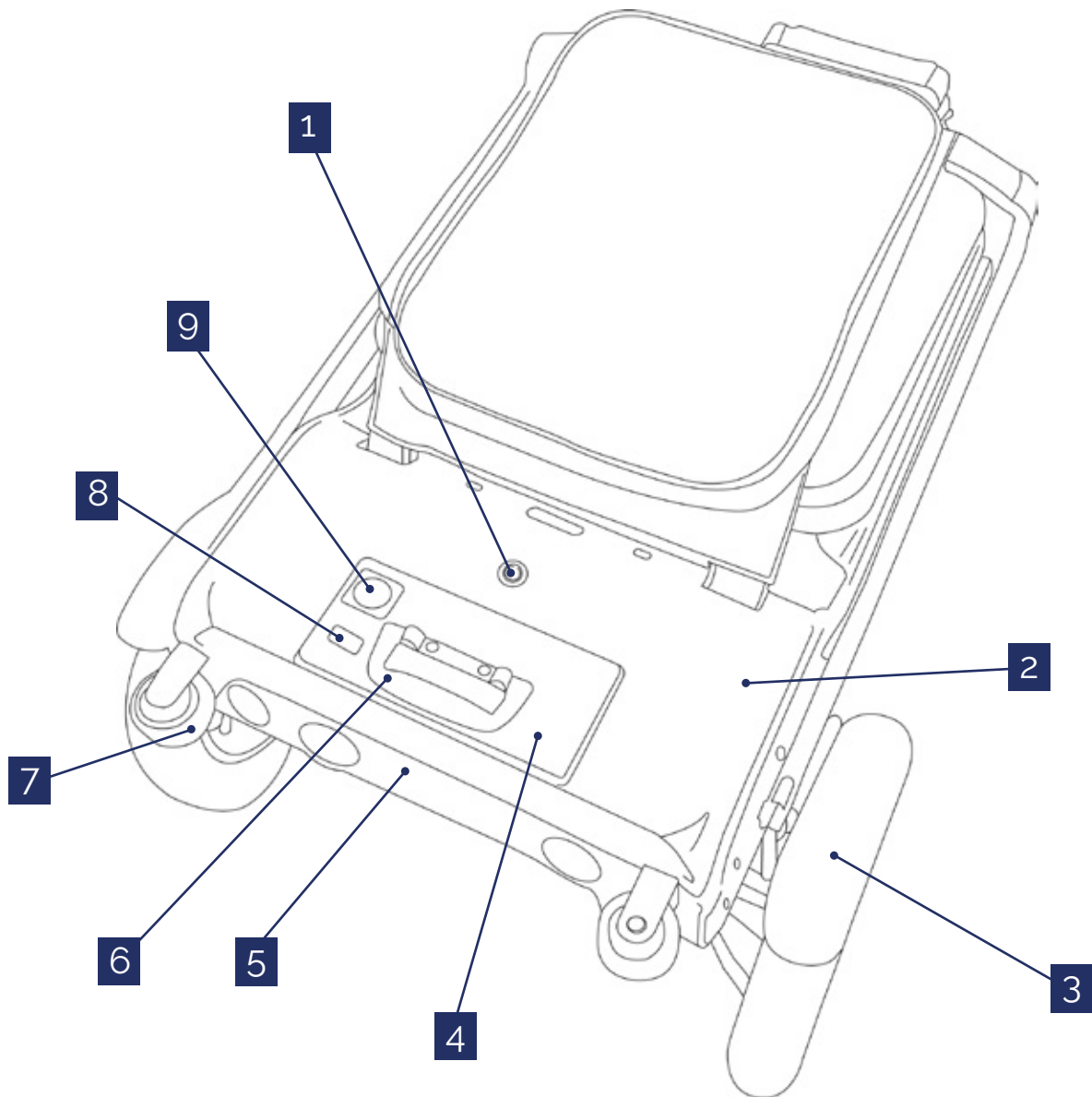

PARTS LIST

1	Battery lock
2	Battery box
3	Rear mudguard
4	Battery
5	Rear light panel
6	Battery handle
7	Suitcase wheels
8	USB Power outlet
9	Charging point

Safety guidance

- It is the users responsibility to read the manual and supplied documents before using the eFOLDi and to follow all of the recommendations contained within, to fully comply with all local laws of their countries and localities and to use the eFOLDi with due diligence and regard to other road users and pedestrians.
- The eFOLDi is simple to use, but its folding mechanism can cause significant injury if used inappropriately and handled without due care and diligence. To avoid any risk of injury ensure hands, fingers, jewellery, clothing and other objects are not allowed to interfere with the folding mechanism or moving parts of the eFOLDi and study the manual carefully before you start operating your eFOLDi.
- It is advised that the user familiarise themselves with the folding and unfolding procedure before venturing outside. The user should also ensure that they familiarise themselves with the controls and handling of the scooter in a safe area away from obstacles and other pedestrians or road users.
- eFOLDi users are recommended to wear appropriate clothing when using a mobility scooter which should include an approved helmet, sturdy shoes or boots, appropriate gloves and high visibility protective clothing as a safety precaution.
- Fully charge the battery(ies) before first use and follow the guidelines in this manual for prolonging the life of your battery.
- Your eFOLDi MK 1.5 should only be stood on its main rear wheels and suitcase wheels when it is on level and stable ground.

CAUTION



When travelling at speeds greater than a slow walking pace be sure to slow down before turning.

Do not ride over rough, cobbled, muddy or loose gravel surfaces. Your eFOLDi is designed for smooth and firm footpaths, roads and pedestrian areas only.

Approach kerbs (maximum height of 3cm) carefully and at right angles and cross them slowly.

Any vehicle can be dangerous to its rider/driver and other road users and pedestrians. Always ride/drive responsibly, respectfully and with due care to others.

Your eFOLDi Scooter is NOT a toy and is not recommended for people under the age of 14. Do not allow children to play with or on the scooter. The internal folding mechanism can cause injury to small hands.

When unfolding/folding your eFOLDi MK 1.5 ensure

- The eFOLDi is positioned on a level floor or ground.
- Main switch is switched off.
- All latch pins are properly secured in place, as stated on the instructions and shown on the illustrations.
- Brake lock is disengaged.

Safety check before use

It is highly recommended that you perform a safety check before each use to make sure your eFOLDi operates smoothly and safely.

Check for correct tyre inflation. Maintain but do not exceed the PSI/BAR/kPa air pressure rating indicated on the pneumatic rear tyres and be sure to use the correct pressure scale and according number on your inflater/tester. ✓

Check all electrical connections. Make sure they are secure and not corroded. ✓

Check and test the brake system. ✓

Check frequently for any loose fasteners, fixings and other components. ✓

Unfolding instructions

STEP 1:

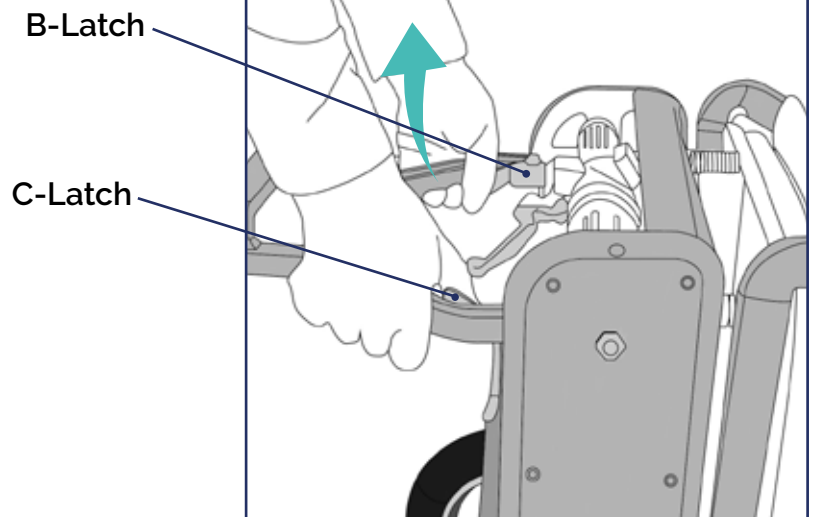
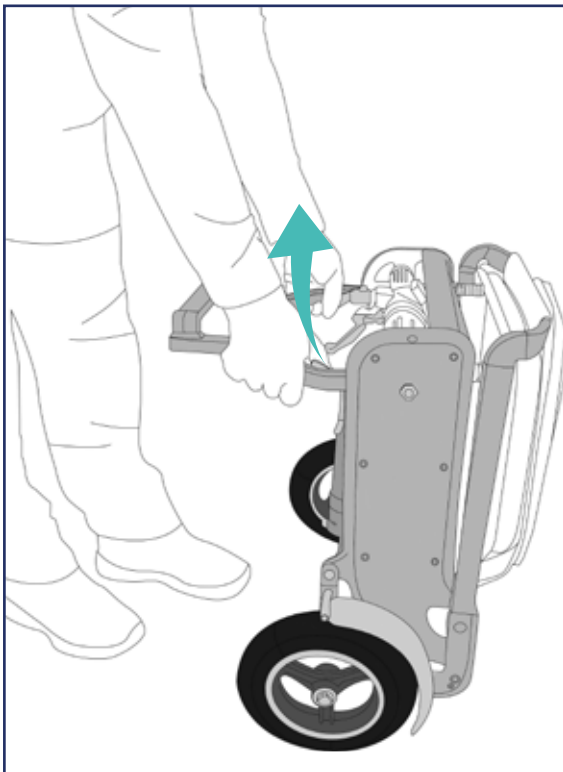

1. Position the eFOLDi MK 1.5 vertically and release the carry/drag handle by pressing the 'B' and 'C' latches. Gently rotate the carry handle to a vertical position.

STEP 2:

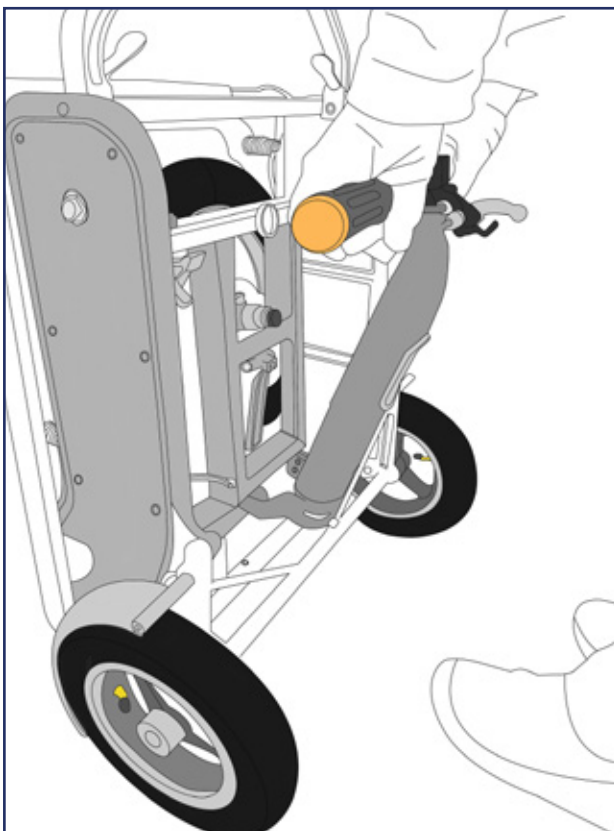

2. Pull the control bar towards you, using a gentle pressure and/or a twisting motion to release this from the magnetic catch that holds it in place.

Unfolding instructions

STEP 3:

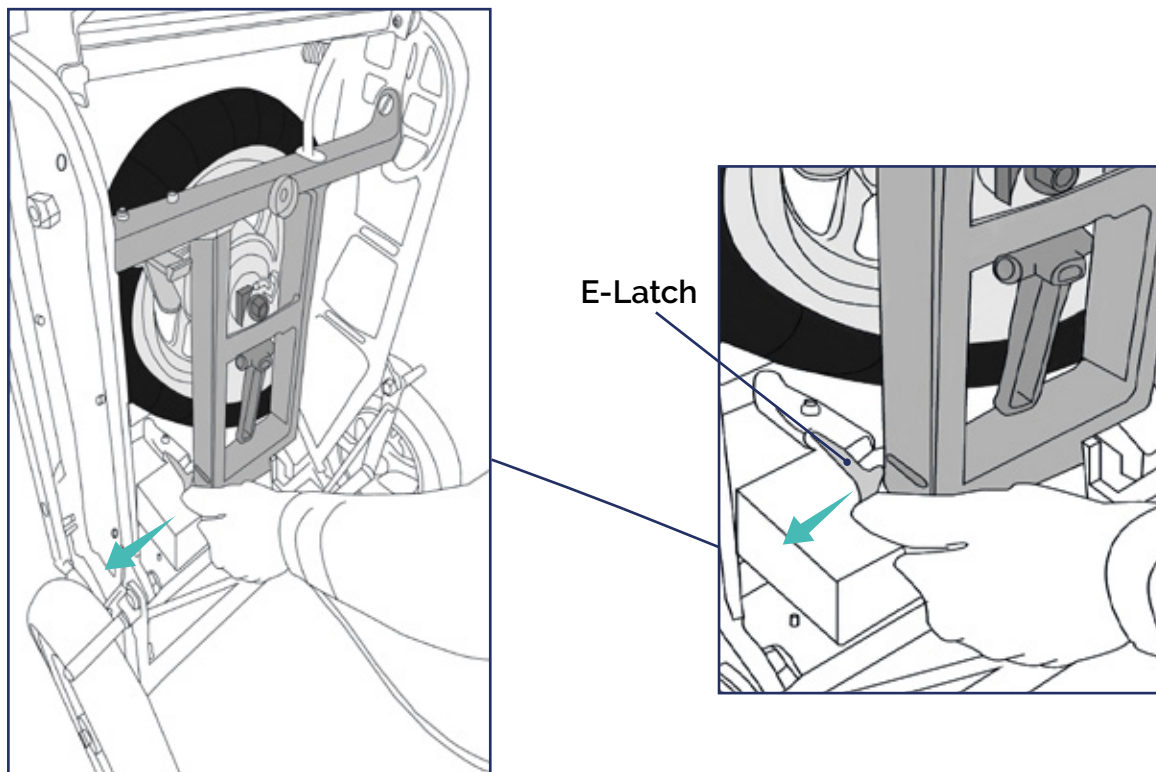

3. Hold the handlebar/steering column with one hand and gently press it towards the frame while releasing the 'E' latch.

STEP 4:

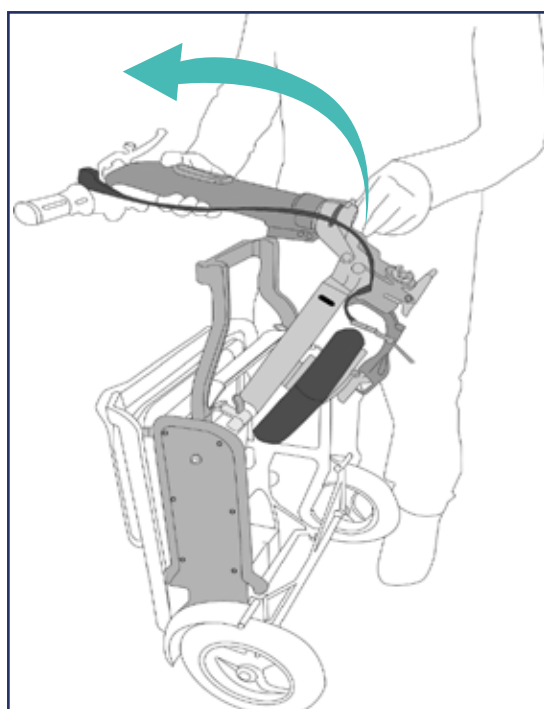

4. Pull the handle/steering column up and over the carry/drag handle.

Unfolding instructions

STEP 5:

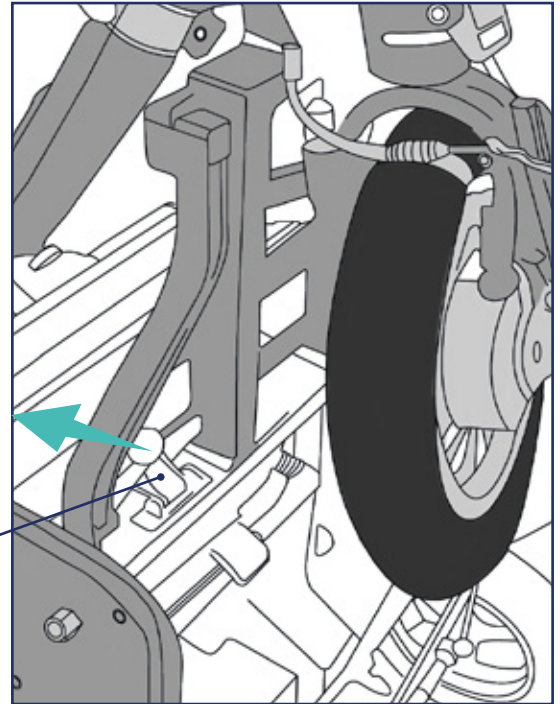
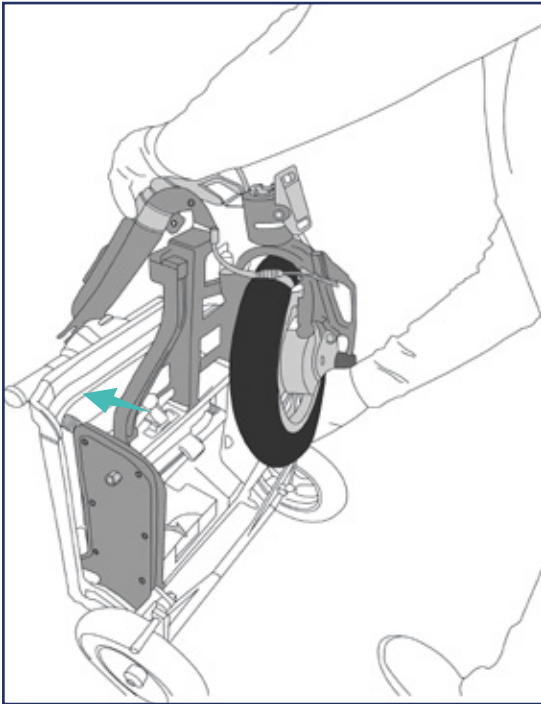

5. Push the handlebar/steering column over until you hear latch 'D' click into place.

STEP 6:

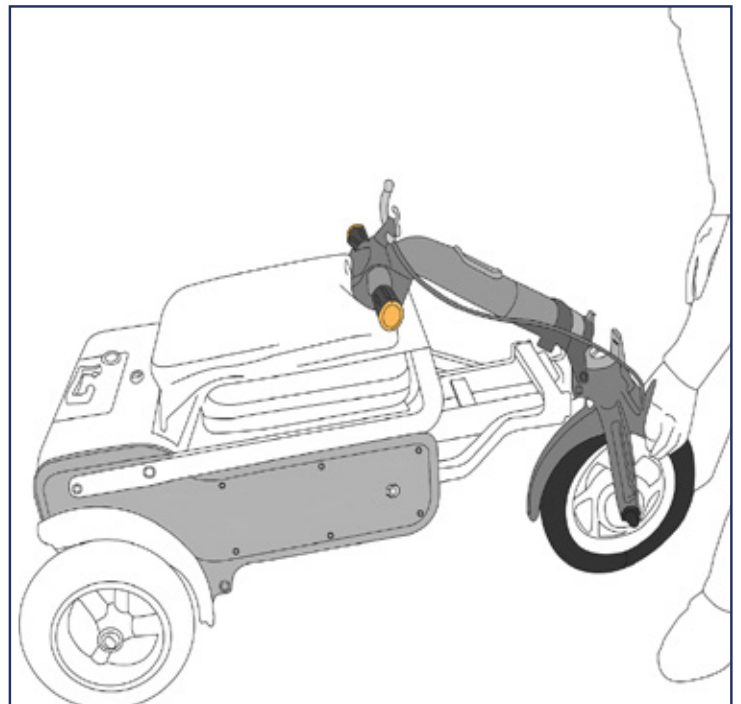
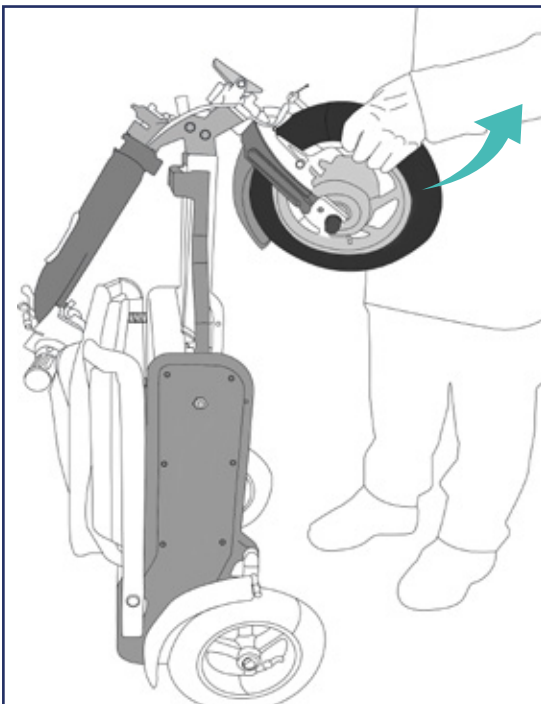

6. Pull the front wheel free of its magnetic catch, by applying gentle pressure, while twisting the wheel to one side and then lower the eFOLDi to the horizontal position.

Unfolding instructions

STEP 7:

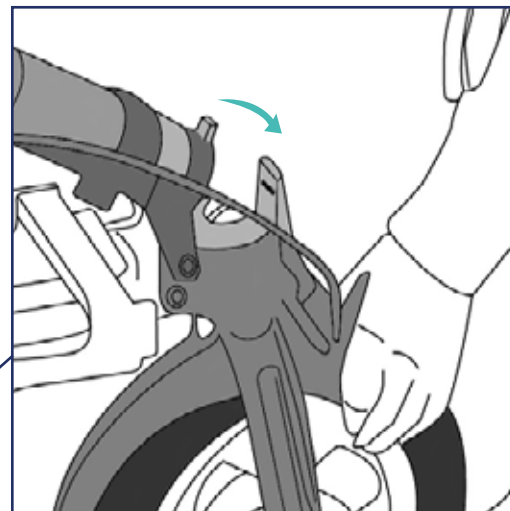
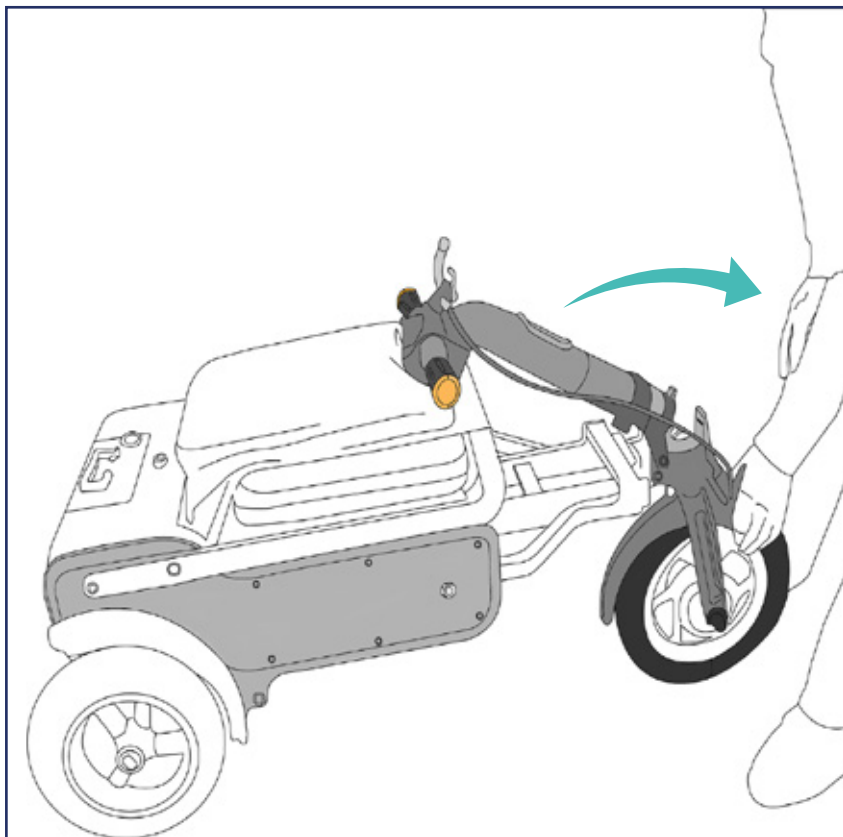

7. In the horizontal position pull the handlebar/steering column upright until you hear the 'A' latch click into place. Note that the steering column is keyed to fit in line with the front wheel.

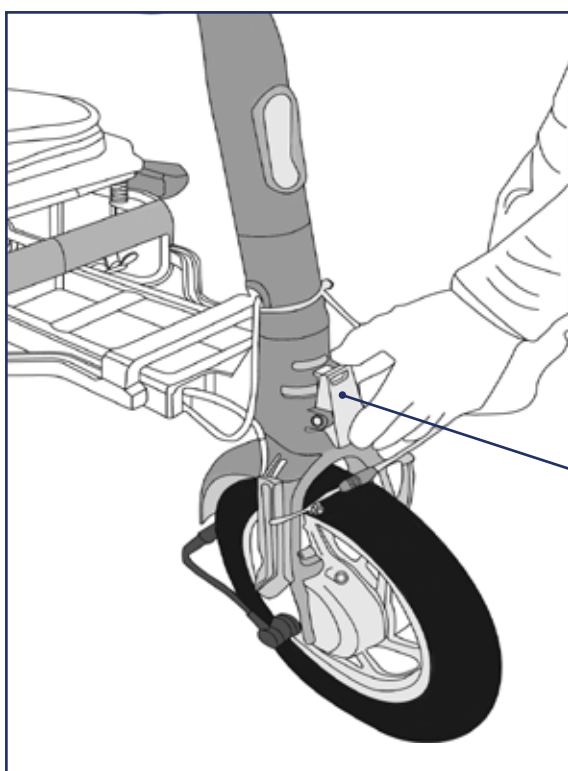

A-Latch

Unfolding instructions

STEP 8:

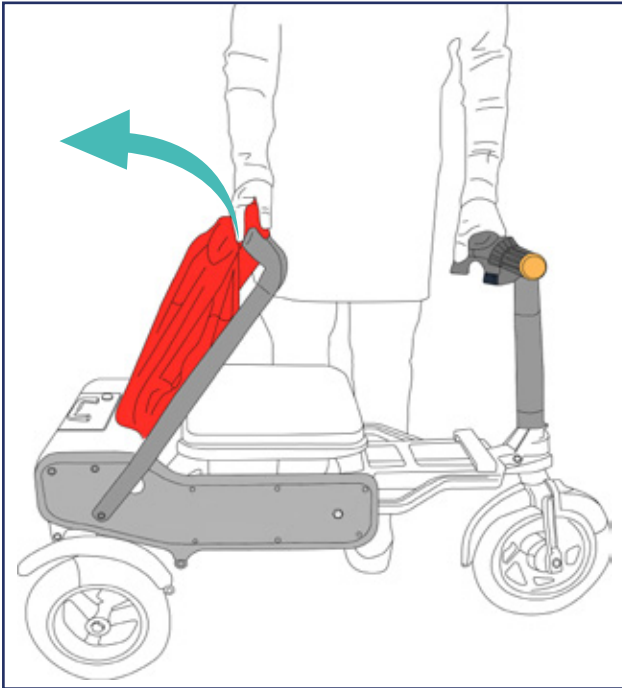

8. Put the seat back upright.

STEP 9:



9. Push the footpegs out from the front wheel



Your eFOLDi scooter is ready for your ride

Folding instructions

STEP 1:

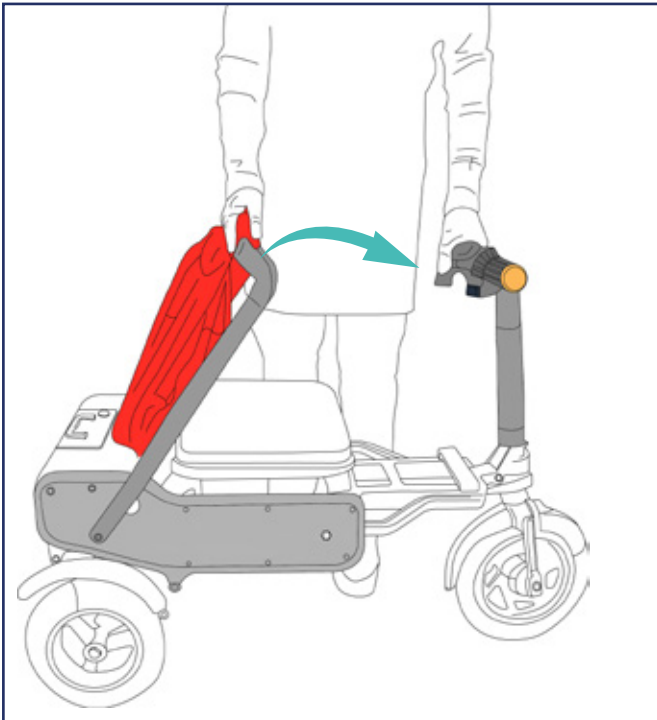

1. Fold the seat back down to a horizontal position flat against the seat cushion.

STEP 2:

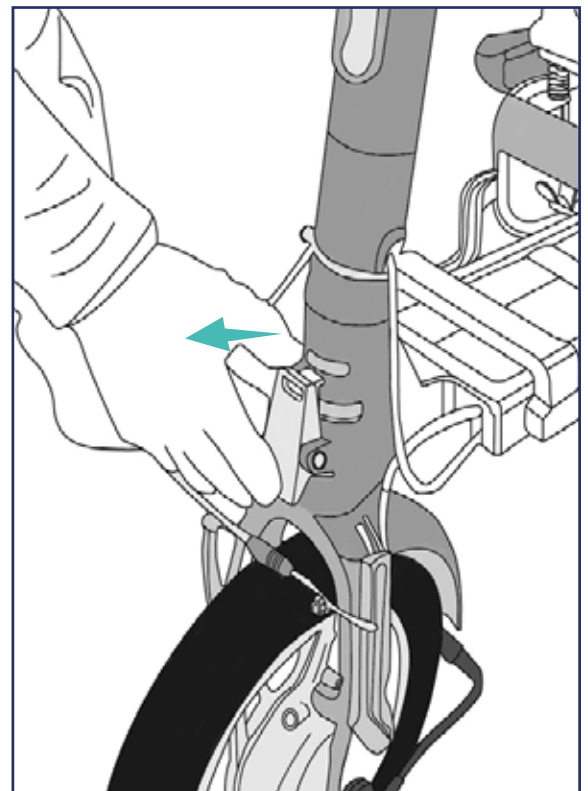
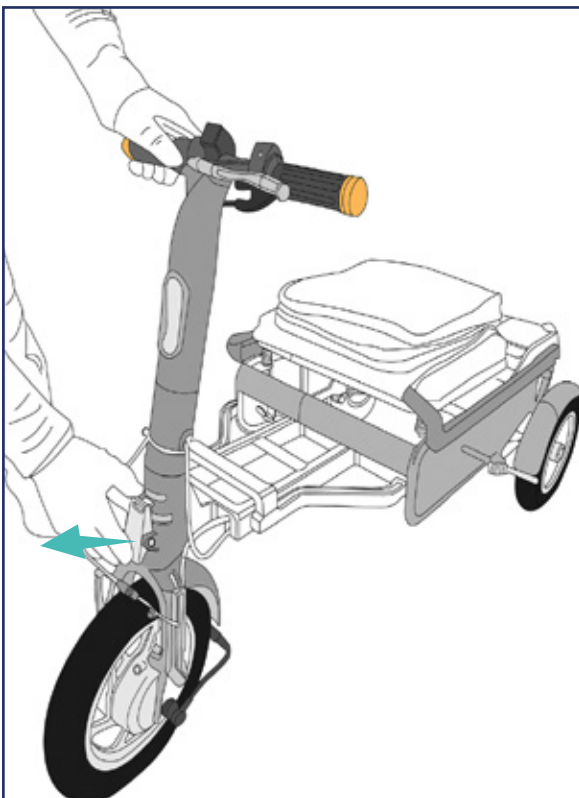

2. Release the handlebar/steering column by pressing in the 'A' latch. Support the steering column while doing this and make sure the brake lock is released.

Folding instructions

STEP 3:

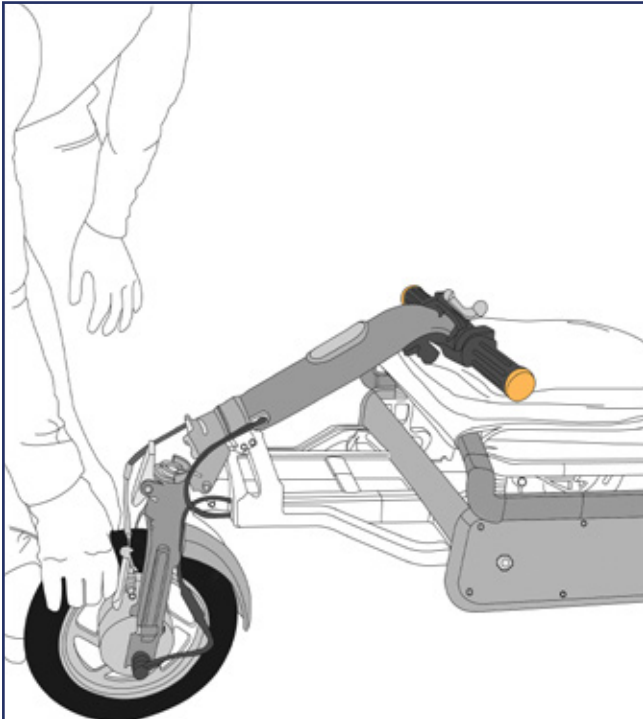

3. Place the steering column flat with the handlebars resting on the seat cushion and lift the eFOLDi to a vertical position.

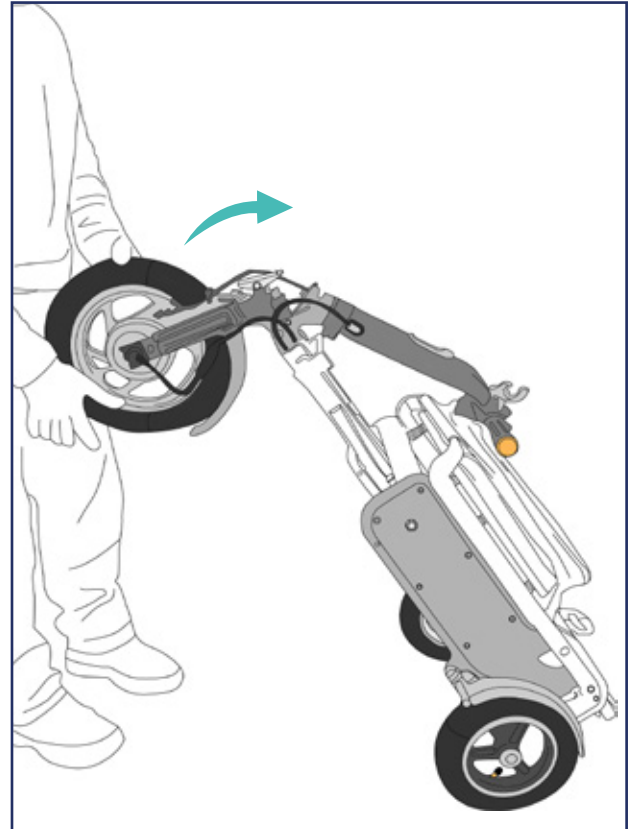

STEP 4:

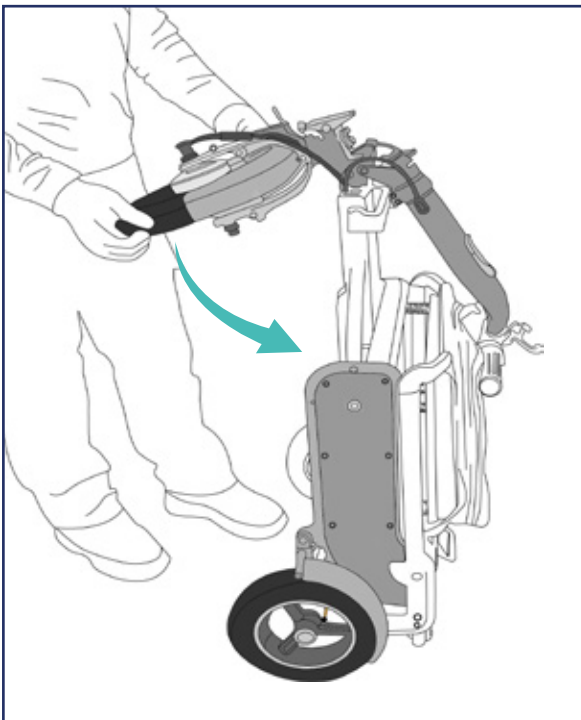

4. Rotate the front wheel so that it can lay flat against carry/drag handle part of the frame. The wheel will lock against its magnetic catch.

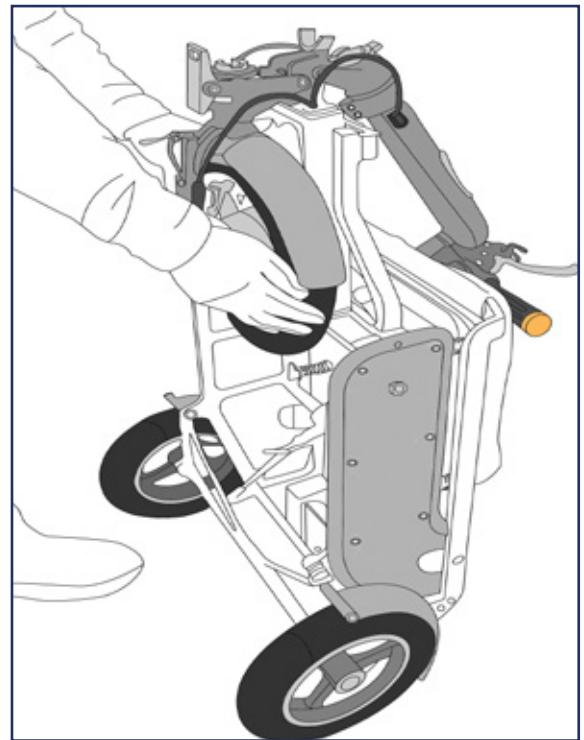

Folding instructions

STEP 5:

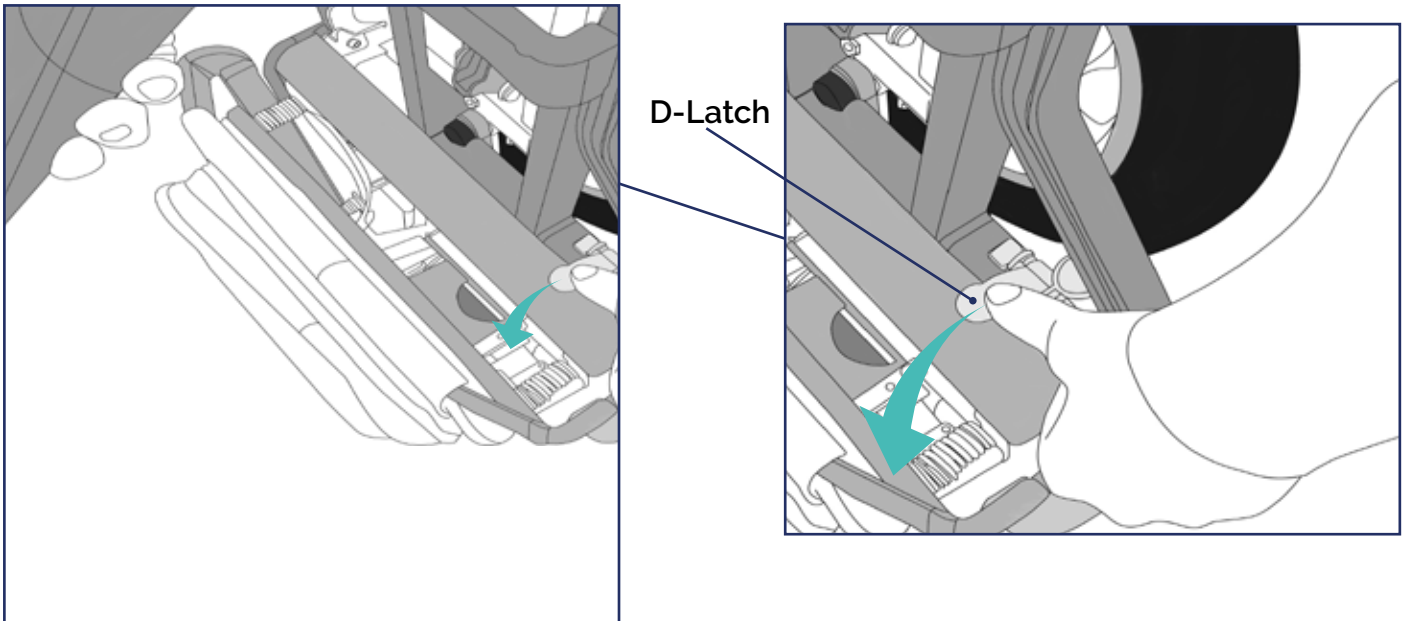

5. While holding the steering column press the 'D' latch which will release the forward part of the frame. Do not press the 'D' latch without holding the steering column.

STEP 6:

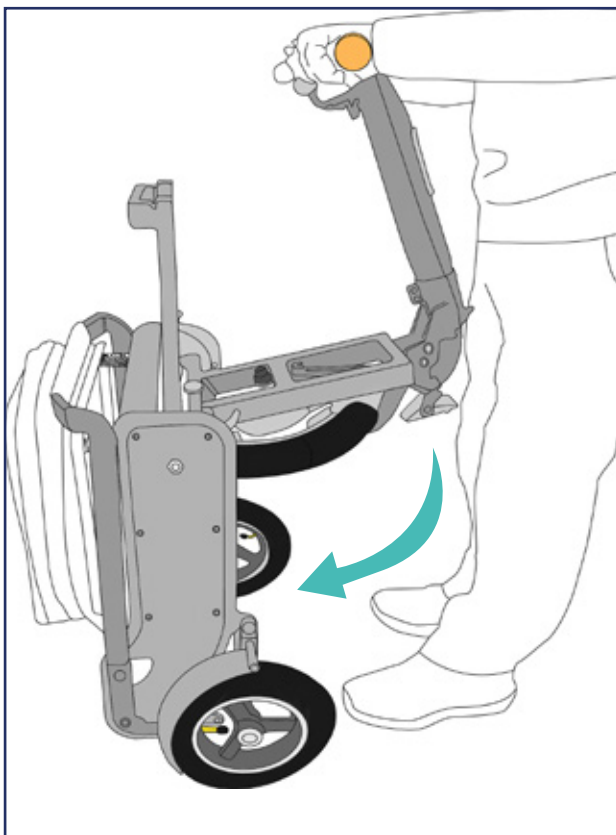

6. Lower the handlebar/steering column and front wheel assembly so that it fits flat against the main body of the scooter.

Folding instructions

STEP 7:

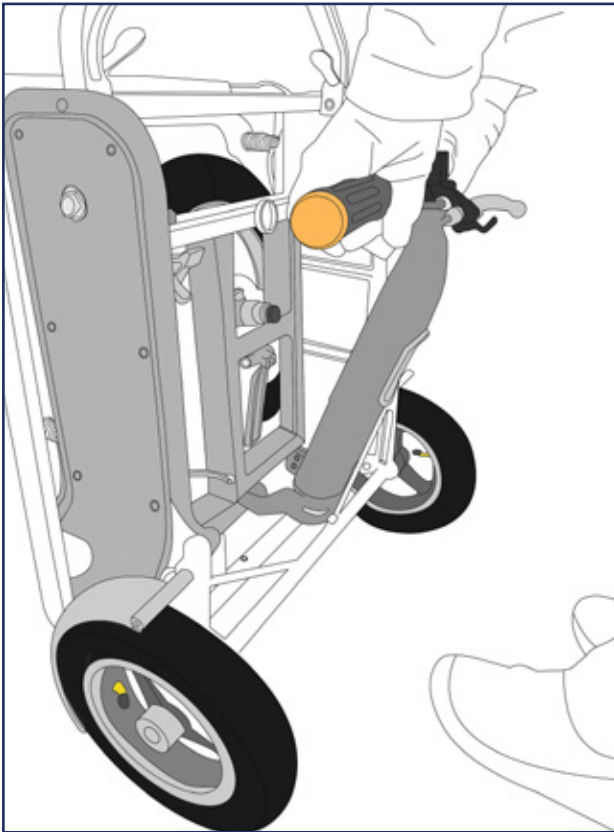

7. Push the folded front wheel and handlebar/steering column in towards the scooter until you hear the 'E' latch click to lock the assembly in place. Push the handlebars in until you feel magnetic catch lock the bars into position.

STEP 8:

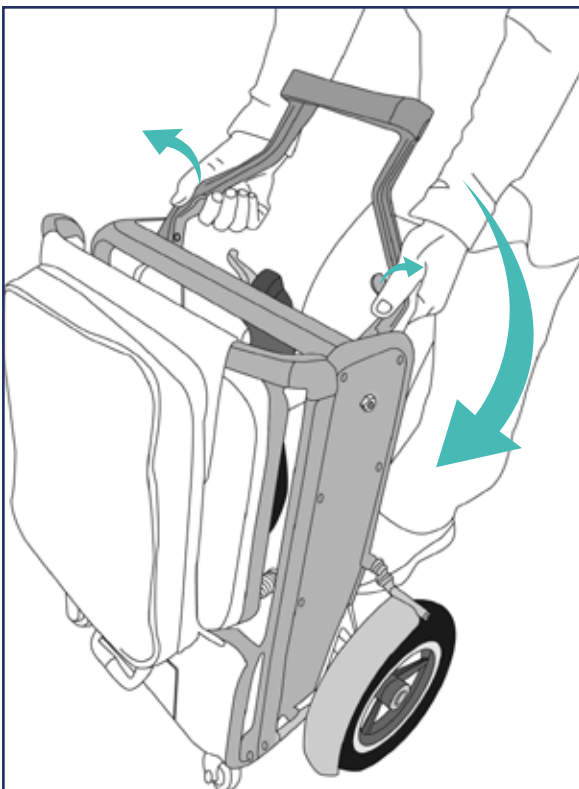

8. Finally fold the carry/drag handle by pressing the 'B' and 'C' latches and rotate the carry handle downwards until it is folded flat against the scooter.

Folding into a chair

STEP 1:

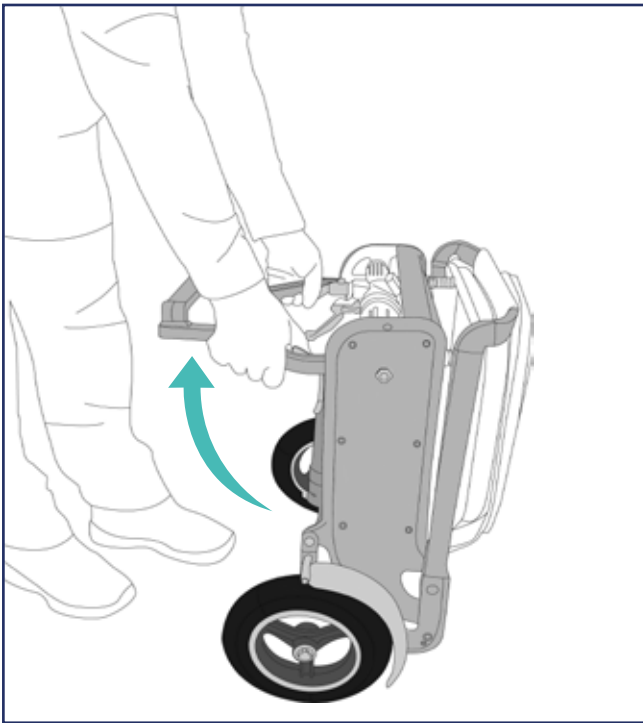

1. Release the carry handle by pressing the 'B' and 'C' latches and pulling the carry/drag handle outwards until it is horizontal.

STEP 2:

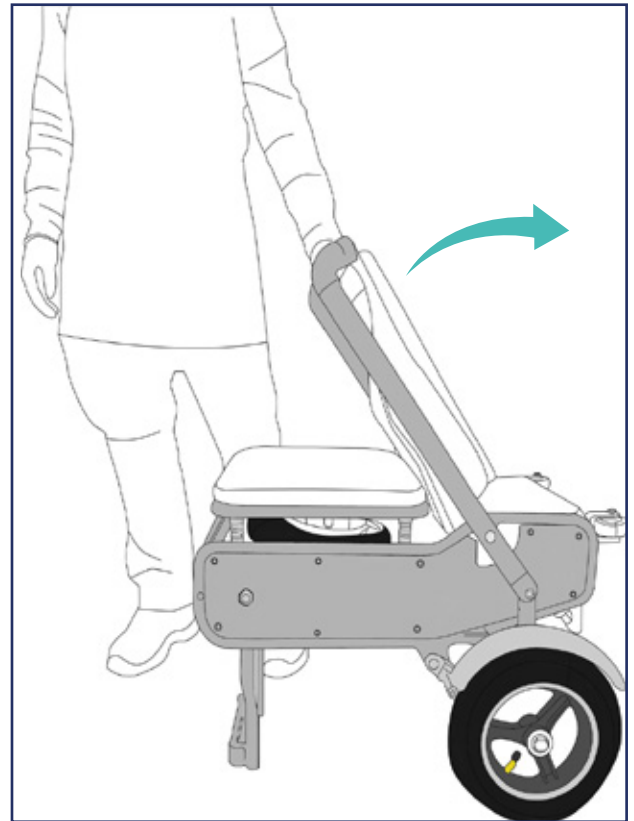

2. Place the eFOLDi down in a horizontal position resting on its rear wheels and the carry/drag handle and finally pull the seat back upright.



How to drive your eFOLDi

When driving your eFOLDi, choose a route with good road conditions. The eFOLDi is designed to drive on smooth even surfaces.

Unevenly paved roads or paths, potholes and other hazards, will reduce the life of any scooter and your safety.

Do not drive on steep roads or excessively cambered roads. The amount of charge remaining in the battery immediately before commencing any slope upward will be crucial to the climbing ability. Any deviation from level/horizontal surfaces should not exceed a gradient of 1:6 (9.5 degrees).

For any climbing there are many factors that need to be considered these are: the tyre pressure and condition, the surface condition (if wet, icy or slippery, and this includes leaf cover and/or other debris, we advise against driving the slope), batteries charge and the weight of the user, all of these will affect performance.



Before driving your eFOLDi make sure:

- You have read the safety guidance on page 10 and 11

How to drive your eFOLDi

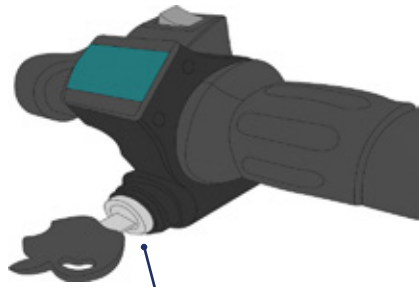

1 Ignition switch

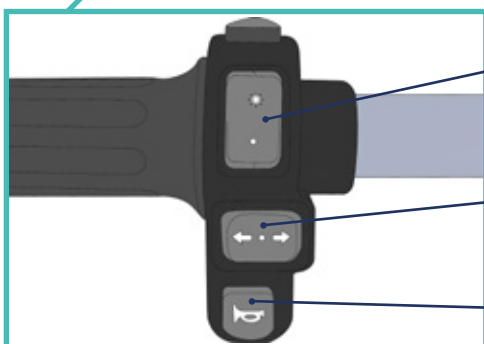
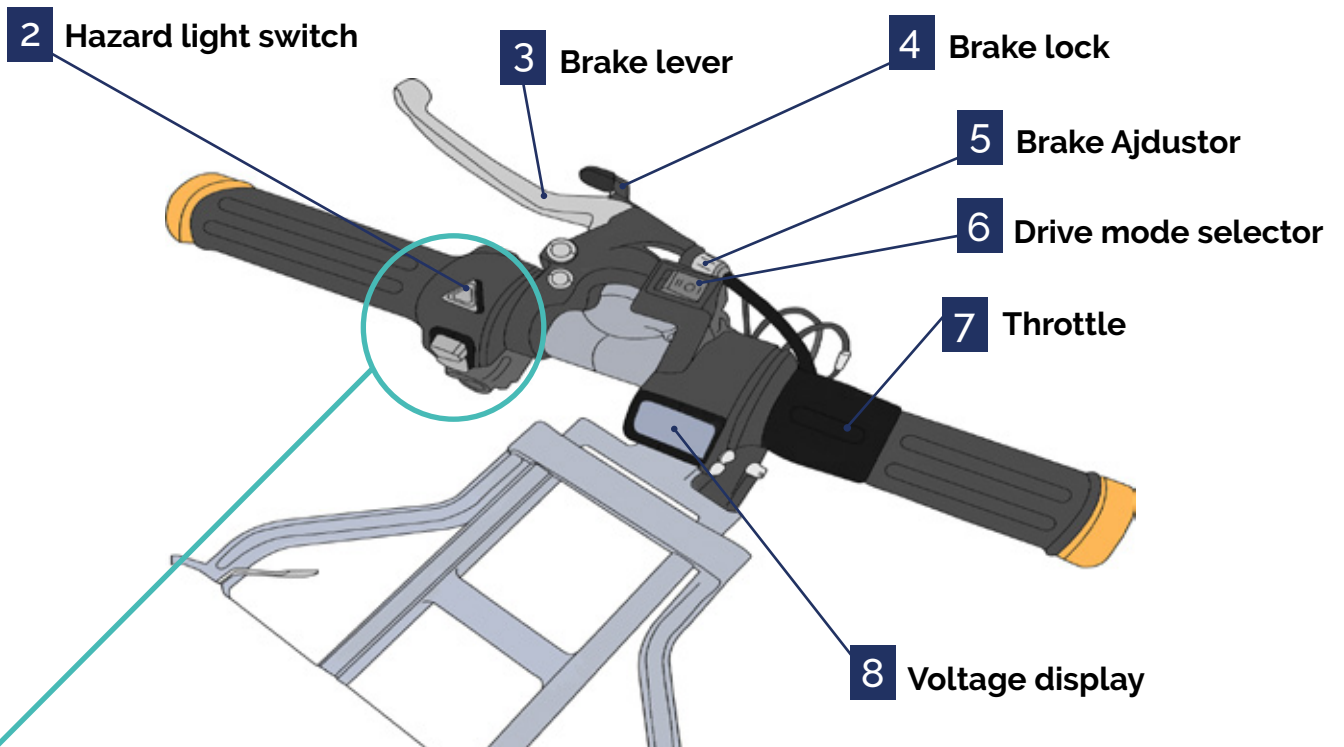

9 Headlight switch

10 Turn indicator switch

11 Horn

- 1 Ignition switch** works with the insertion of the key into the key slot, to switch on the eFOLDi the key will need to be turned clockwise from the 9 to 11 o'clock position.
- 2 Hazard light** it is positioned on the centre left side of the control bar, works by pressing the triangular button with a white double triangle. With the ignition on, a continual beeper sounds when operated.
- 3 Brake lever** works by pulling the silver lever on the centre left of the control bar. When the brake lever is applied power to the motor is cut off and brake lights illuminate.
- 4 Brake lock** is positioned in front of the brake lever, and it works by pulling the brake lever and pulling the brake lock inwards.
- 5 Brake adjustor** This small ring is positioned slightly to the left of the brake lever/brake cable tension. Turn this anti-clockwise to increase brake tension to suit your driving style.
- 6 Drive mode selector** The drive mode selector has three positions to control maximum speed and direction.
 - 1 - Pavement mode - Maximum speed (4mph)
 - 11 - Road mode - Maximum speed (8mph)
 - 0 - Reverse - Slow speed (warning indicators flash and sounder emits a warning tone)
- 7 Throttle** Twist the inner ring to apply power for driving either forwards or reverse.
- 8 Voltage Display** shows the voltage battery level. Recharge the battery when it drops to 24V.
- 9 Headlight switch** is positioned in the centre left side of the control bar and operates the head and rear warning lights.
- 10 Turn Indicator switch** is positioned in the centre left side of the control bar, under the headlight switch and turns the right or left indicator lights on (front and back).
- 11 Horn** is positioned underneath the indicator switch and will sound the horn.

Battery info and charging



The eFOLDi 1.5 battery has been designed and built specifically for the eFOLDi 1.5 . This battery must not be used for any purpose other than as stated in this manual. Any misuse or dismantling of this battery may damage it physically and/or electrically, internally and/or externally will not be covered by warranty.

The battery contains no user serviceable or replaceable components.

The eFOLDi 1.5 battery is actually a battery pack, comprising a number of lithium/ion cells, but merely termed 'battery' for ease throughout this manual. This battery is different in characteristics and charging requirements to the old and still quite common lead/acid or lead/gel type. Never use a lead type charger to charge it.

To ensure best long-term use of the battery, please observe the following safety rules at all times

- Connection dock must be handled with care to avoid damage.
- Charge the battery only with the approved charger.
- Never use a charger for lead type batteries on the eFOLDi battery.
- Never place the battery near, on or against any heat source.
- Ensure no metal parts can touch (or 'short') battery or charger terminals, connectors, pins or any other electrical conductor(s) or conducting parts.
- Avoid excessive physical impact and vibration of the battery.
- Do not attempt to dismantle, dissect or deform the battery(ies) or case(s).
- Do not immerse the battery in any liquid (including water).
- Do not mix different types of batteries.
- Keep the battery out of reach of children.
- Do not use modified or damaged chargers.
- Do not leave the battery on charge for more than 24 hours.
- Store the battery in a cool, dry, well ventilated area.
- Dispose of the battery only in accordance with local laws and regulations.
- If the battery is not used often, it is preferable to give it a short 'top up' charge every 2-3 months.
- Never store the battery when it is significantly discharged.

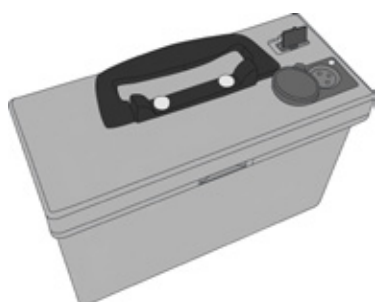

Battery info and charging

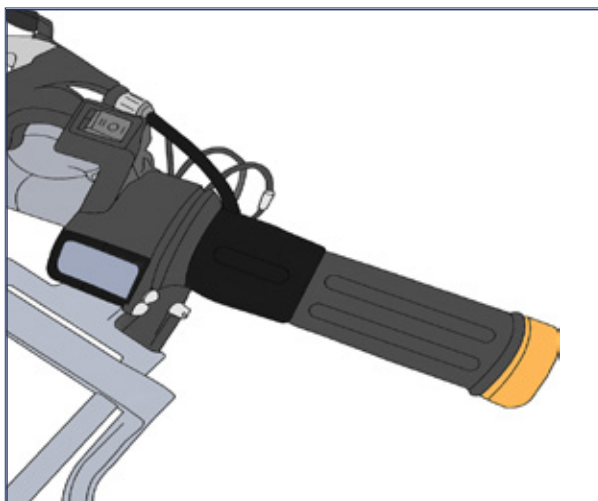

The eFOLDi 1.5 battery level indicator is the voltage display.

Once the power is switched on with the key switch the battery level should be reading 29 Volts or above, which signifies a fully charged battery and this will give the eFOLDi a range of 14 miles / 22 kilometres.

CAUTION

Do not allow the battery to discharge lower than 23 Volts in any instance - irreparable damage or reduction in useful life of the battery is likely to occur.

Fitting the battery into the eFOLDi



For an efficient battery removal, make sure that the main power is switched off and use the supplied battery key to unlock the battery. Use the battery handle to pull the battery upward whilst using the palm of your other hand to push the back panel down and away.

NB: Ensure that the battery is UNLOCKED with the supplied key before attempting removal.

Tips for prolonging battery performance and life.

If the battery is not used often, it is preferable to give it a short 'top-up' charge, e.g. every 2-3 months. The battery should be charged as soon as is possible after every use. Never store the battery significantly discharged.

Battery info and charging



Charger and charging

Precaution for use and handling charger

Use only the charger originally supplied with your new eFOLDi or replacement charger supplied by SunTech UK Ltd for the use with the eFOLDi. The use of a non-approved charger will invalidate any warranty and may cause serious damage to the battery and/or your eFOLDi. The charger should not be used with or for other devices as damage caused to the charger and/or any other device by doing so will not be covered by our warranty.

It is highly recommended to ensure the charger is placed only on a heat resistant surfaces and nothing which could contribute to a fire (e.g. carpet, floorboards, wood, laminate or plastic worktops and so on)- the charger will heat up during a normal charging cycle, as will the battery.

Do not leave the battery on charge for more than 24 hours, as this will reduce the life and performance of the battery.

Charging notes for international travellers

For the benefit of international travellers, your approved eFOLDi charger can be used with any mains voltage supply from 100 to 240 Volts, with a suitable travel adaptor.

Using the charger

*Before obtaining an alternative cable, it is recommended you examine your eFOLDi charger to determine which type of plug it requires - it will be either a two -pin 'figure of 8' (IEC60320-1 C7), or a three-pin similar to a kettle (IEC60320-1 C13).





Perform the following inspections prior to using your eFOLDi daily:

- Make sure you check the correct tyre inflation and maintain without exceeding the P.S.I./BAR/kPa air pressure rating indicated on each pneumatic tyre (note; the front and rear tyres are different pressures). Also be sure to use the correct pressure scale and according number on your inflater/pressure tester.

Perform the following inspections weekly:

- Check the brakes and make sure all the parts of the brakes are working properly.
- Make sure the handle brake lock is working properly before driving.
- Check the fastening condition of each nuts, bolts and screws to make sure all the parts are properly secured and are not missing or loose
- Check all electrical connections. Make sure they are tight and not corroded.
- **Have your eFOLDi regularly serviced each year.**

Cleaning and maintenance

Periodic cleaning of your eFOLDi will help to maintain its appearance and will both extend the life of the vehicle and improve resale value. Metal and plastic parts can be wiped with a damp cloth using a mild detergent. Use a soft lint free cloth to polish.



CAUTION

**Oil and other lubricants must not be used on the following parts:
Brake pads, brake cable, tyres.**

Frequently asked questions



■ How much does my eFOLDi weigh?

Your eFOLDi weighs 17 Kg / 37lbs.

■ How much weight can my eFOLDi scooter carry?

The eFOLDi scooter can carry up to 120kg/265lbs

■ How fast does my eFOLDi travel?

Up to 4mph in slow speed gear switch and 8mph in fast speed gear switch. This depends on many factors, including conditions of terrain, slope angle, load weight and weather conditions. The throttle is sensitive to how much you twist it, so if you don't want to go at full speed you don't have to twist it all the way.

■ What tyre pressure should I pump my tyres up to?

This does depend upon the intended terrain and the weight of the load, but we recommend 30 PSI on each of the 3 tyres for a comfortable ride in most conditions.

■ What size inner tubes will I need if I did get a puncture?

12" for the front and 10" for the rear.

■ How do I change the front tyre/inner tube?

Pinch and release the brake cable just above the front wheel. Unclip the electric cable and then use a spanner to undo the wheel nuts. Then the front wheel will drop out from the forks for you to be able to replace either the tyre or the inner tube. This is best done with a set of tyre levers. Once you have replaced the tyre or inner tube, repeat the same process in reverse.

■ What sort of braking system does my eFOLDi have?

The brake is a standard cable rim brake, just like on a bicycle. Over time and usage, the cable will stretch and the brake blocks will wear. Once you notice any performance loss, it is recommended that you book your eFOLDi in for a service.

To engage the brake lock, pull on the brake lever and then push the lock into place. Never fold your eFOLDi with the brake lock on, as this will cause damage to the mechanism.

■ How long does the battery take to charge?

Up to 5 hours. It is recommended to charge when the voltage display reads less than 24. When it is fully charged it will read 29.2

■ What do the keys do?

The flat keys are the ignition keys, which insert into the eFOLDi next to the throttle. The rounded keys are the battery keys and release and lock the battery into its compartment at the rear of the scooter.

Frequently asked questions



■ **Where is the battery on my eFOLDi scooter located?**

The battery is located in the compartment behind the back rest

■ **Can I charge my eFOLDi with the battery left in?**

Yes, it is up to you if you would prefer to charge the battery either in, or out of the eFOLDi.

■ **How far will the eFOLDi scooter go on a charge?**

The range is impacted by a number of factors in respect of surface and tyre conditions but will travel up to 22km/14 miles on dry even surfaces.

■ **What do I do if the seat springs squeak?**

Spray the seat bolts and springs with a PTFE spray, which will stop any squeaking.

■ **Is the handlebar or seat height adjustable?**

No, neither are able to be adjusted.

■ **Can I take my eFOLDi on an aeroplane?**

Yes. You can drive your eFOLDi up to the cabin doors, where you will be asked to take out the battery and keep it with you for the duration of the flight. The main scooter will be taken to a secure part of the hold by the cabin crew and returned to you when you land.

■ **Do I need to register my eFOLDi with the DVLA? (UK only)**

Yes, your eFOLDi MK1.5 is a class 3 mobility scooter and should be registered with the DVLA (if you intend to use it on the road). Please find our helpful guide and pre-filled form included with the manual and welcome pack. Just follow the simple steps and post it off to complete registration.



Technical specifications

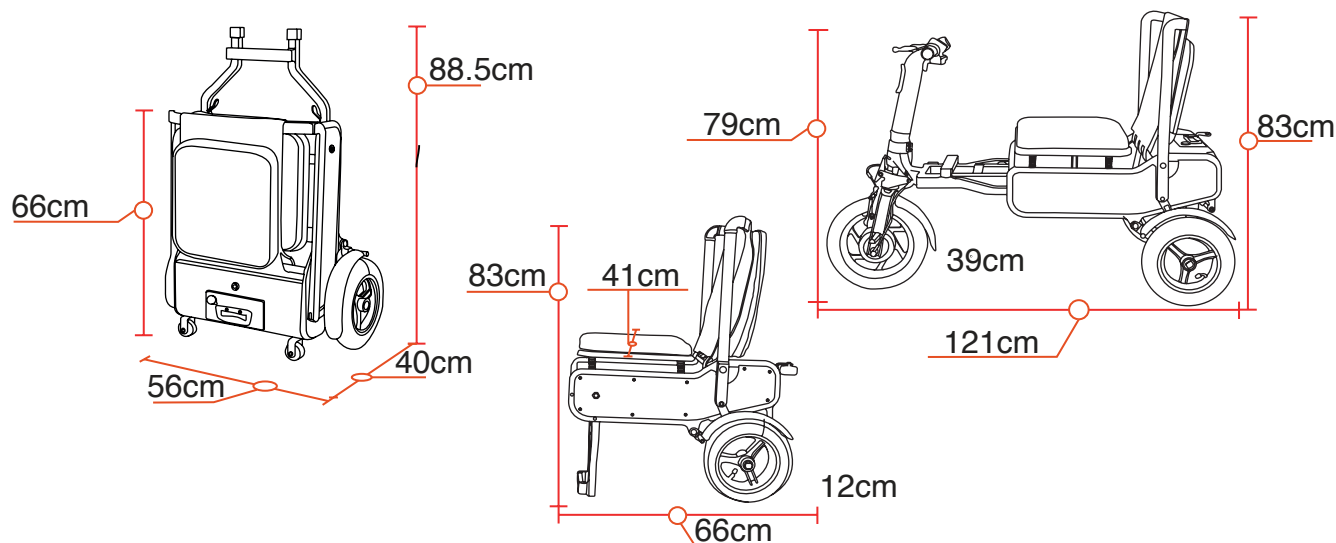

DIMENSIONS

Fold dimensions (L/W/H): 66x56x40cm (26x22x15.6')

Unfold dimensions (L/W/H): 121x56x83cm (47.6x22x32.6')

Chair dimensions (L/W/H): 66x56x83cm (26x22x32.6')

Packaging dimensions (L/W/H): 60x44x75cm (24x17x29.5')

Seat height: 48.5cm/19'

Footrest height: 22cm/8.6'

Front wheel size/pressure: 30cm (12") / 30 psi

Rear wheel size/pressure: 25cm (10") / 30 psi

Ground clearance: 12cm/4.7'

WEIGHT

Weight with battery: 17kg/(37lbs)

Weight without battery: 15kg/(33lbs)

PERFORMANCE

Speed: 4mph/(6kmh) - 8mph/(12kmh)

Maximum range capacity: 14miles/22km

Maximum carry capacity: 120kg/265lbs

Maximum Incline: 1:6 Gradient (9.5 degrees)

COMPONENTS CAPABILITY

Motor: 240W 24V Hub Motor

Battery standard: 12Ah Li-Ion

Brake: Mechanical

Main switch: Electronic Key operated

Lights: Front Headlight

Number of wheels: 3

Turning radius Minimum left: 102cm/40'

Turning radius Minimum right: 85cm/33'

ENVIRONMENT

Place to use: Pavement and indoor

Appendix



SunTech UK Ltd

25 Ormside Way, Holmethorpe Industrial Estate, Redhill, Surrey, RH1 2LW











TEL: +44 (0) 2031435168



MedPath GmbH

Mies-van-der-Rohe-Strasse 8, 80807 Munich, Germany

Symbol used on the Label

	Conformite Europeenne		Manufacturer
	Authorized representative in the European Community		Medical device
	Serial number		UDI
	Date of Manufacture		Refer to instructions manual
	Avoid sunlight		Keep dry



SunTech UK Ltd
25 Ormside Way, Redhill
Surrey, RH1 2LW, UK



MedPath GmbH
Mies-van-der-Rohe-Strasse 8
80807 Munich, Germany

www.efoldi.com

Services@efoldi.com

Version: MK1.5 05052021